

CONSTRUCTION ENTRANCE  
PER BMP C105

NO STAGING OR STORAGE WITHIN  
RIGHT-OF-WAY  
ALL STAGING AND STORAGE TO  
TAKE PLACE WITHIN LIMITS OF WORK

ISLAND CREST WAY

REMOVE EXISTING HOME,  
DRIVEWAY  
AND WALKWAYS

SILT FENCE AND HI-VIZ  
LIMIT OF WORK FENCE  
PER BMP C233 AND  
BMP C103

SEE C2 FOR TESC DETAILS

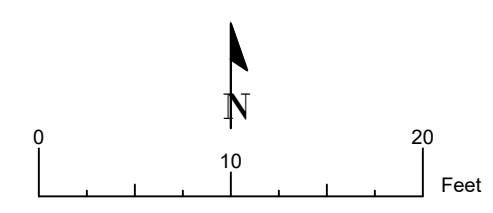

4102 Island Crest Way SFR  
Site Address: 4102 Island Crest Way  
Jurisdiction: Mercer Island  
Parcel No.: 545030-0025  
Applicant: Hien Phan  
Permit No.:  
Interlaken Project No.: SEA-22-190

Interlaken Engineering and Design, PLLC  
Seattle, WA | (206) 470-9572  
www.interlakenengineering.com

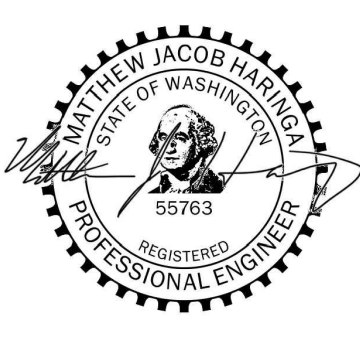

Revisions:

**C1**  
TESC/ Demo/ CSWPPP  
Scale: 1" = 10'

**Figure II-3.1: Stabilized Construction Access**

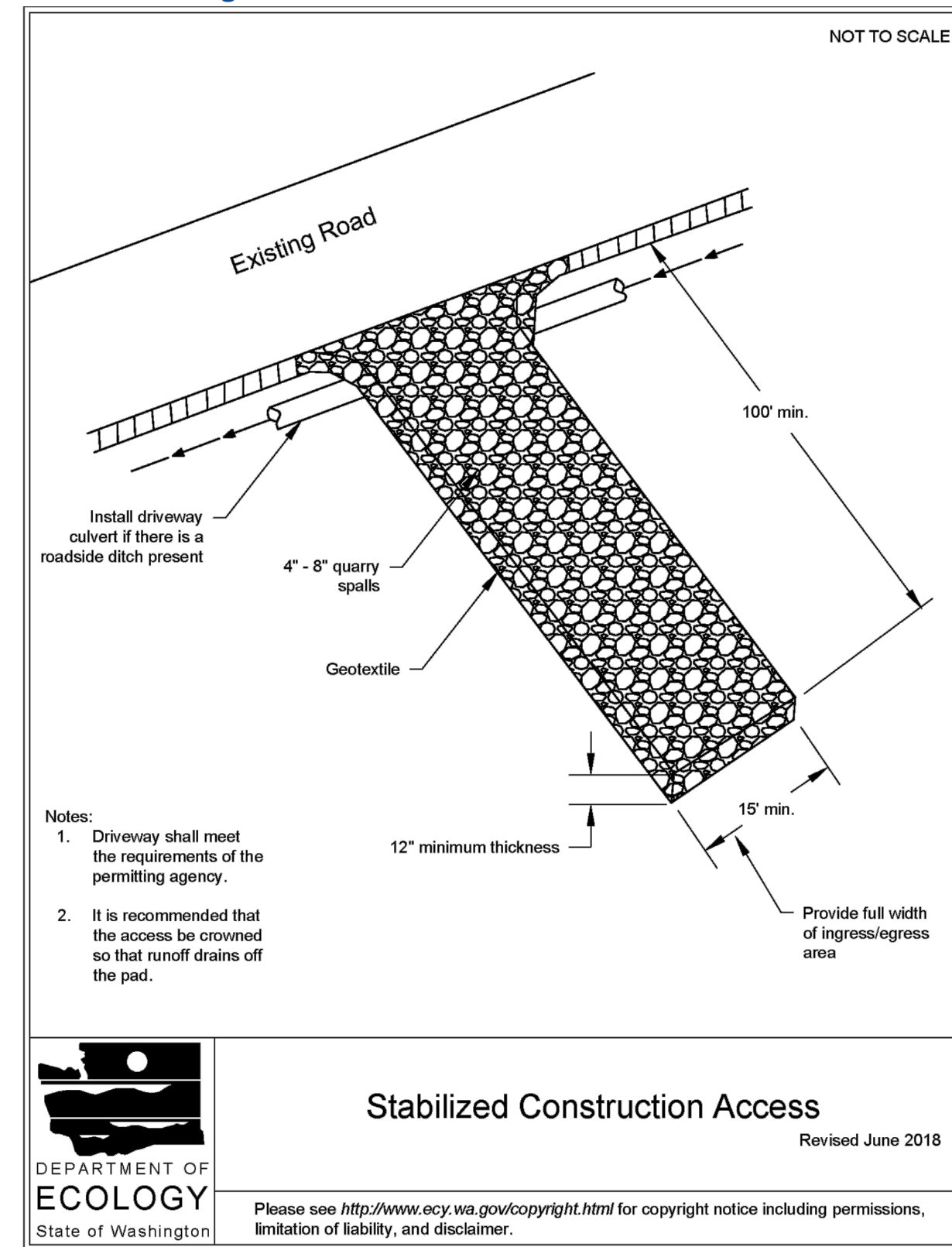

2019 Stormwater Management Manual for Western Washington  
Volume II - Chapter 3 - Page 279

**Figure II-3.22: Silt Fence**

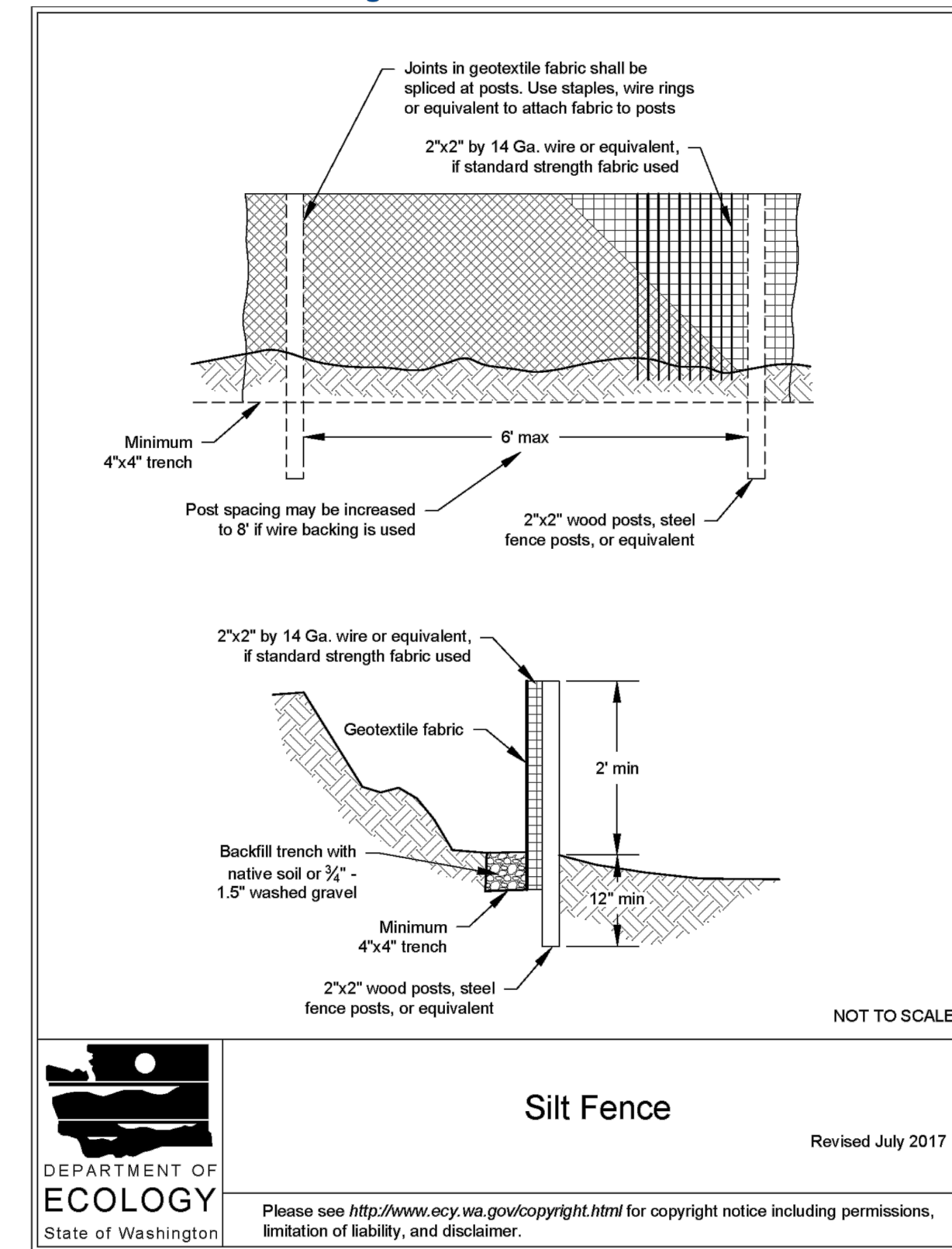

2019 Stormwater Management Manual for Western Washington  
Volume II - Chapter 3 - Page 371

SEE C1 FOR TESC/ DEMO/ CSWPPP

4102 Island Crest Way SFR  
Site Address: 4102 Island Crest Way  
Jurisdiction: Mercer Island  
Parcel No.: 545030-0025  
Applicant: Hien Phan  
Permit No.:  
Interlaken Project No.: SEA-22-190



Interlaken Engineering and Design, PLLC  
Seattle, WA | (206) 470-9572  
[www.interlakenengineering.com](http://www.interlakenengineering.com)

Revisions:

**C2**

TESC/ CSWPPP Details

Scale: As Noted

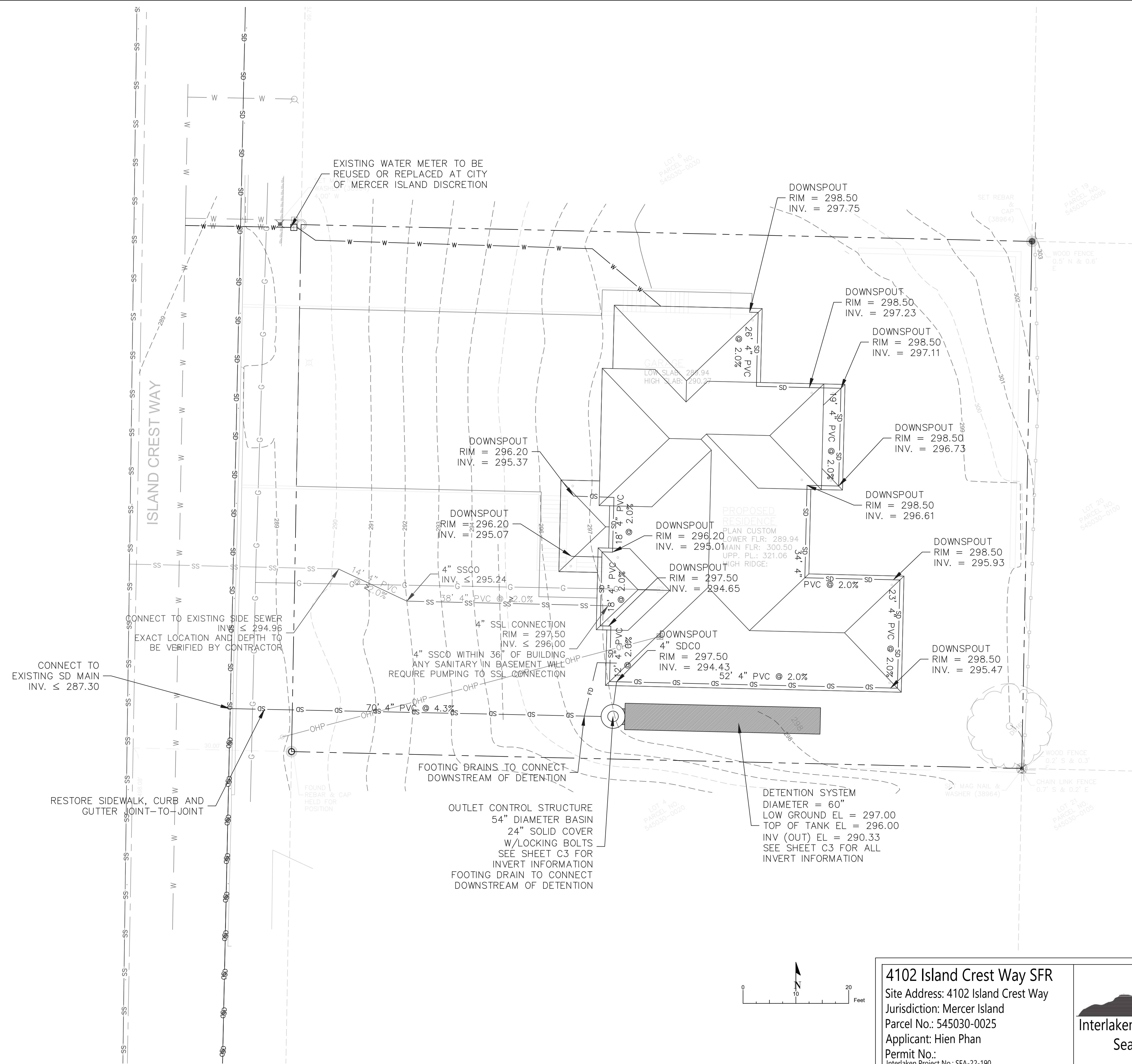

THE LAWN AND LANDSCAPE AREAS ARE REQUIRED TO PROVIDE POST-CONSTRUCTION SOIL QUALITY AND DEPTH IN ACCORDANCE WITH BMP T5.13. THE PROJECT CIVIL ENGINEER MUST PROVIDE A LETTER OF CERTIFICATION TO ENSURE THAT THE LAWN AND LANDSCAPE AREAS ARE MEETING THE POST-CONSTRUCTION SOIL QUALITY AND DEPTH REQUIREMENTS SPECIFIED ON THE APPROVED PLAN SET PRIOR TO FINAL INSPECTION ON THE PROJECT.

ALL AREAS SUBJECT TO CLEARING AND GRADING THAT HAVE NOT BEEN COVERED BY IMPERVIOUS SURFACE, INCORPORATED INTO A DRAINAGE FACILITY OR ENGINEERED AS STRUCTURAL FILL OR SLOPE SHALL, AT PROJECT COMPLETION, DEMONSTRATE THE FOLLOWING:

1. A TOPSOIL LAYER WITH A MINIMUM ORGANIC MATTER CONTENT OF 10% DRY WEIGHT IN PLANTING BEDS, AND 5% ORGANIC MATTER CONTENT IN TURF AREAS, AND A PH FROM 6.0 TO 8.0 OR MATCHING THE PH OF THE UNDISTURBED SOIL. THE TOPSOIL LAYER SHALL HAVE A MINIMUM DEPTH OF EIGHT INCHES EXCEPT WHERE TREE ROOTS LIMIT THE DEPTH OF INCORPORATION OF AMENDMENTS NEEDED TO MEET THE CRITERIA. SUBSOILS BELOW THE TOPSOIL LAYER SHOULD BE SCARIFIED AT LEAST 4 INCHES WITH SOME INCORPORATION OF THE UPPER MATERIAL TO AVOID STRATIFIED LAYERS, WHERE FEASIBLE.
2. MULCH PLANTING BEDS WITH 2 INCHES OF ORGANIC MATERIAL.
3. USE COMPOST AND OTHER MATERIALS THAT MEET THESE ORGANIC CONTENT REQUIREMENTS:
  - A. THE ORGANIC CONTENT FOR "PRE-APPROVED" AMENDMENT RATES CAN BE MET ONLY USING COMPOST MEETING THE COMPOST SPECIFICATION FOR BIORETENTION (BMP T7.30), WITH THE EXCEPTION THAT THE COMPOST MAY HAVE UP TO 35% BIOSOLIDS OR MANURE. THE COMPOST MUST ALSO HAVE AN ORGANIC MATTER CONTENT OF 40% TO 65%, AND A CARBON TO NITROGEN RATIO BELOW 25:1. THE CARBON TO NITROGEN RATIO MAY BE AS HIGH AS 35:1 FOR PLANTINGS COMPOSED ENTIRELY OF PLANTS NATIVE TO THE PUGET SOUND LOWLANDS REGION.
  - B. CALCULATED AMENDMENT RATES MAY BE MET THROUGH USE OF COMPOSTED MATERIAL MEETING (A) ABOVE; OR OTHER ORGANIC MATERIALS AMENDED TO MEET THE CARBON TO NITROGEN RATIO REQUIREMENTS, AND NOT EXCEEDING THE CONTAMINANT LIMITS IDENTIFIED IN TABLE 220-B. TESTING PARAMETERS, IN WAC 173-350-220.

THE RESULTING SOIL SHOULD BE CONDUCTIVE TO THE TYPE OF VEGETATION TO BE ESTABLISHED.

IMPLEMENTATION OPTIONS: THE SOIL QUALITY DESIGN GUIDELINES LISTED ABOVE CAN BE MET BY USING ONE OF THE METHODS LISTED BELOW:

1. LEAVE UNDISTURBED NATIVE VEGETATION AND SOIL, AND PROTECT FROM COMPACTION DURING CONSTRUCTION.
2. AMEND EXISTING SITE TOPSOIL OR SUBSOIL EITHER AT DEFAULT "PRE-APPROVED" RATES, OR AT CUSTOM CALCULATED RATES BASED ON TESTS OF THE SOIL AND AMENDMENT.
3. STOCKPILE EXISTING TOPSOIL DURING GRADING, AND REPLACE IT PRIOR TO PLANTING. STOCKPILED TOPSOIL MUST ALSO BE AMENDED IF NEEDED TO MEET THE ORGANIC MATTER OR DEPTH REQUIREMENTS, EITHER AT A DEFAULT "PRE-APPROVED" RATE OR AT A CUSTOM CALCULATED RATE.
4. IMPORT TOPSOIL MIX OF SUFFICIENT ORGANIC CONTENT AND DEPTH TO MEET THE REQUIREMENTS. MORE THAN ONE METHOD MAY BE USED ON DIFFERENT PORTIONS OF THE SAME SITE. SOIL THAT ALREADY MEETS THE DEPTH AND ORGANIC MATTER QUALITY STANDARDS, AND IS NOT COMPACTED, DOES NOT NEED TO BE AMENDED.

PRE-APPROVED AMENDMENT METHOD:  
 TURF: 5468 SF x 5.4 CY / 1,000 SF = 29.5 CY  
 TOTAL QUANTITY = 29.5 CY

Hard Surface Data	
Lot Size	13,796 sf
New Roof	3,338 sf
New Driveway+Walkway	2,130 sf
Total Proposed Hard Surface	5,468 sf
Proposed Vegetation	8,328 sf

**SEE C1 FOR TESC/ DEMO CSWPPP**  
**SEE C4 FOR DETENTION DETAILS**

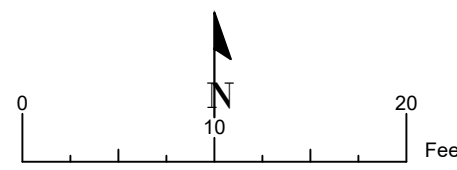

4102 Island Crest Way SFR  
 Site Address: 4102 Island Crest Way  
 Jurisdiction: Mercer Island  
 Parcel No.: 545030-0025  
 Applicant: Hien Phan  
 Permit No.:  
 Interlaken Project No.: SEA-22-190

Interlaken Engineering and Design, PLLC  
 Seattle, WA | (206) 470-9572  
 www.interlakenengineering.com



Revisions:	

**C3**  
 Drainage Site Plan  
 Scale: 1" = 10'

**ATTACHMENT 1**  
**CITY OF MERCER ISLAND**  
**ON-SITE DETENTION SYSTEM WORKSHEET**  
**(FOR NEW PLUS REPLACED IMPERVIOUS**  
**AREA OF 9,500 SF OR LESS)**

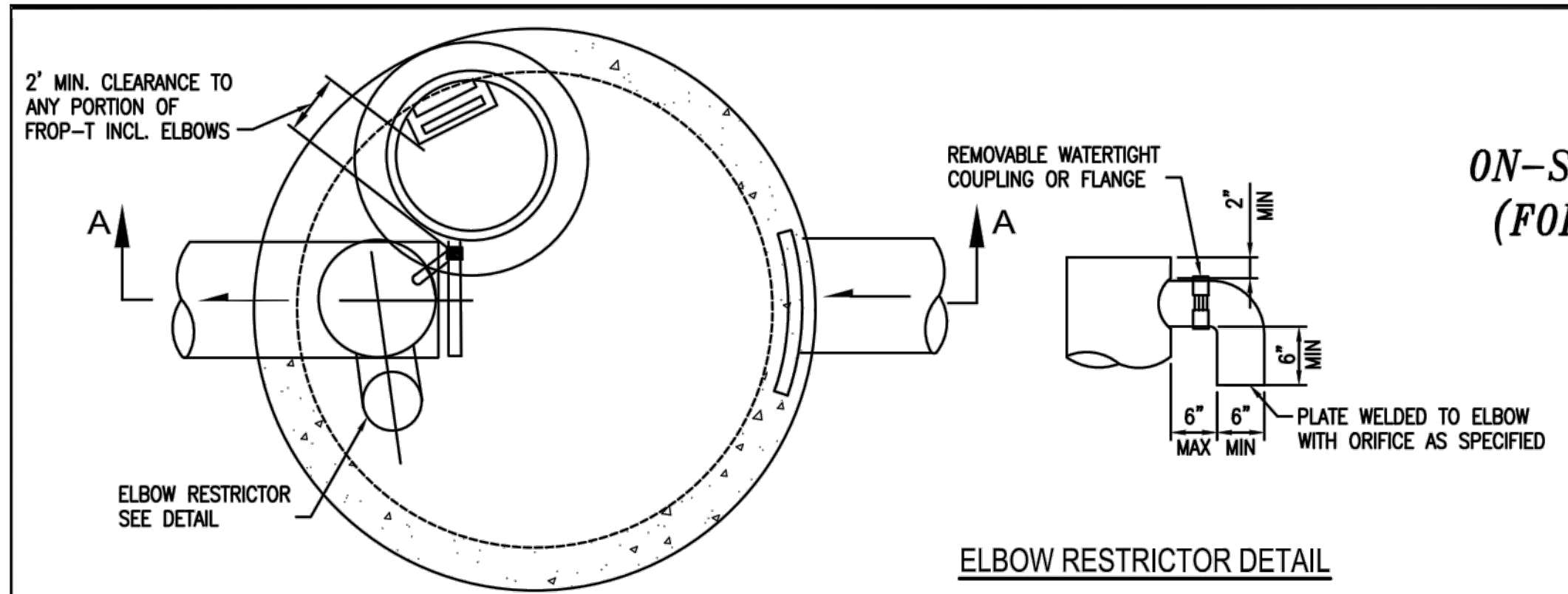

ELBOW RESTRICTOR DETAIL

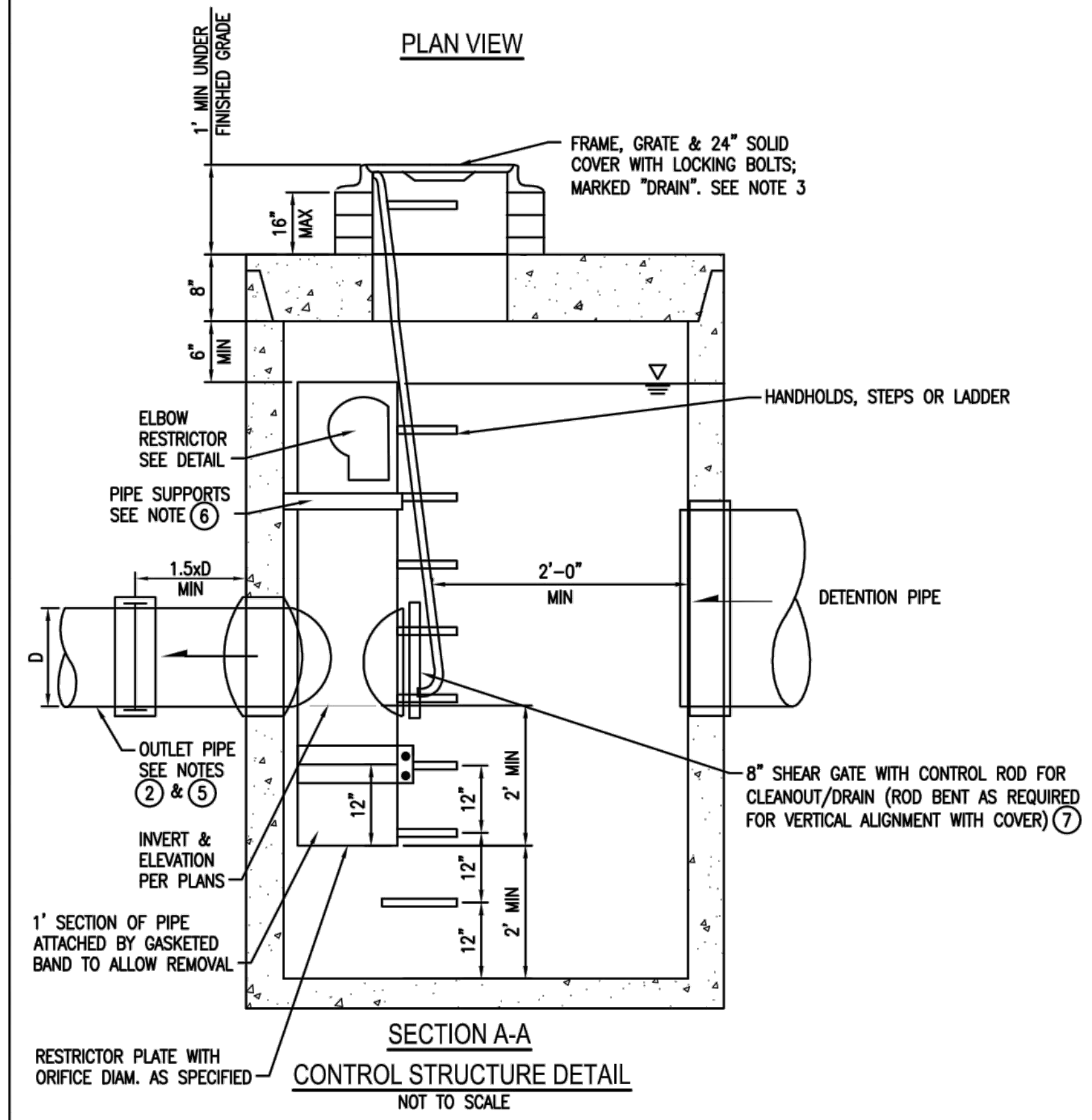

SECTION A-A  
CONTROL STRUCTURE DETAIL  
 NOT TO SCALE

CONTROL STRUCTURE NOTES:

- |  |   |
|--|---|
| <p>① USE A MINIMUM OF A 54 IN. DIAM. TYPE 2 CATCH BASIN. THE ACTUAL SIZE IS DEPENDENT ON CONNECTING PIPE MATERIAL AND DIAMETER.</p> <p>② OUTLET PIPE: MIN. 6 INCH.</p> <p>③ METAL PARTS: CORROSION RESISTANT. NON-GALVANIZED PARTS PREFERRED. GALVANIZED PIPE PARTS TO HAVE ASPHALT TREATMENT 1.</p> <p>④ FRAME AND LADDER OR STEPS OFFSET SO:<br/>         A. CLEANOUT GATE IS VISIBLE FROM TOP;<br/>         B. CLIMB-DOWN SPACE IS CLEAR OF RISER AND CLEANOUT GATE;<br/>         C. FRAME IS CLEAR OF CURB.</p> <p>⑤ IF METAL OUTLET PIPE CONNECTS TO CEMENT CONCRETE PIPE, OUTLET PIPE TO HAVE SMOOTH O.D. EQUAL TO CONCRETE PIPE I.D. LESS 1/4 IN.</p> | <p>⑥ PROVIDE AT LEAST ONE 3 X 0.090 GAUGE SUPPORT BRACKET ANCHORED TO CONCRETE WALL WITH 5/8 IN. STAINLESS STEEL EXPANSION BOLTS OR EMBEDDED SUPPORTS 2 IN. INTO CATCH BASIN WALL (MAXIMUM 3'-0" VERTICAL SPACING).</p> <p>⑦ THE SHEAR GATE SHALL BE MADE OF ALUMINUM ALLOY IN ACCORDANCE WITH ASTM B 26M AND ASTM B 275, DESIGNATION ZG32A; OR CAST IRON IN ACCORDANCE WITH ASTM A 48, CLASS 30B. THE LIFT HANDLE SHALL BE MADE OF A SIMILAR METAL TO THE GATE (TO PREVENT GALVANIC CORROSION), IT MAY BE OF SOLID ROD OR HOLLOW TUBING, WITH ADJUSTABLE HOOK AS REQUIRED. A NEOPRENE RUBBER GASKET IS REQUIRED BETWEEN THE RISER MOUNTING FLANGE AND THE GATE FLANGE. INSTALL THE GATE SO THAT THE LEVEL-LINE MARK IS LEVEL WHEN THE GATE IS CLOSED. THE MATING SURFACES OF THE LID AND THE BODY SHALL BE MACHINED FOR PROPER FIT. ALL SHEAR GATE BOLTS SHALL BE STAINLESS STEEL.</p> <p>⑧ THE UPPER CATCH BASIN IS REQUIRED IF THE LENGTH OF THE DETENTION PIPE IS GREATER THAN 50 FT.</p> |
|--|---|

OWNER: <u>Hien Phan</u>	ADDRESS: <u>4102 Island Crest Way</u>	PREPARED BY: <u>Interlaken Engineering and Design, PLLC</u>
PERMIT #:		PHONE: <u>(206) 470-9572</u>
		DATE: <u>February 21, 2023</u>
NEW PLUS REPLACED IMPERVIOUS SURFACE AREA (SF): <u>5,468 sf</u>	DETENTION PIPE DIA (INCH): <u>60</u>	DETENTION PIPE LENGTH (FT): <u>37</u>
SOIL TYPE: <u>C</u>	PIPE MATERIAL: <u>ADS</u>	ORIFICE #1 DIA <u>0.5</u> INCH, ELEV <u>287.83</u>
		ORIFICE #2 DIA <u>1.4</u> INCH, ELEV <u>294.58</u>

NO UPPER CATCH BASIN REQUIRED -  
 DETENTION PIPE LENGTH IS LESS THAN 50 FT.

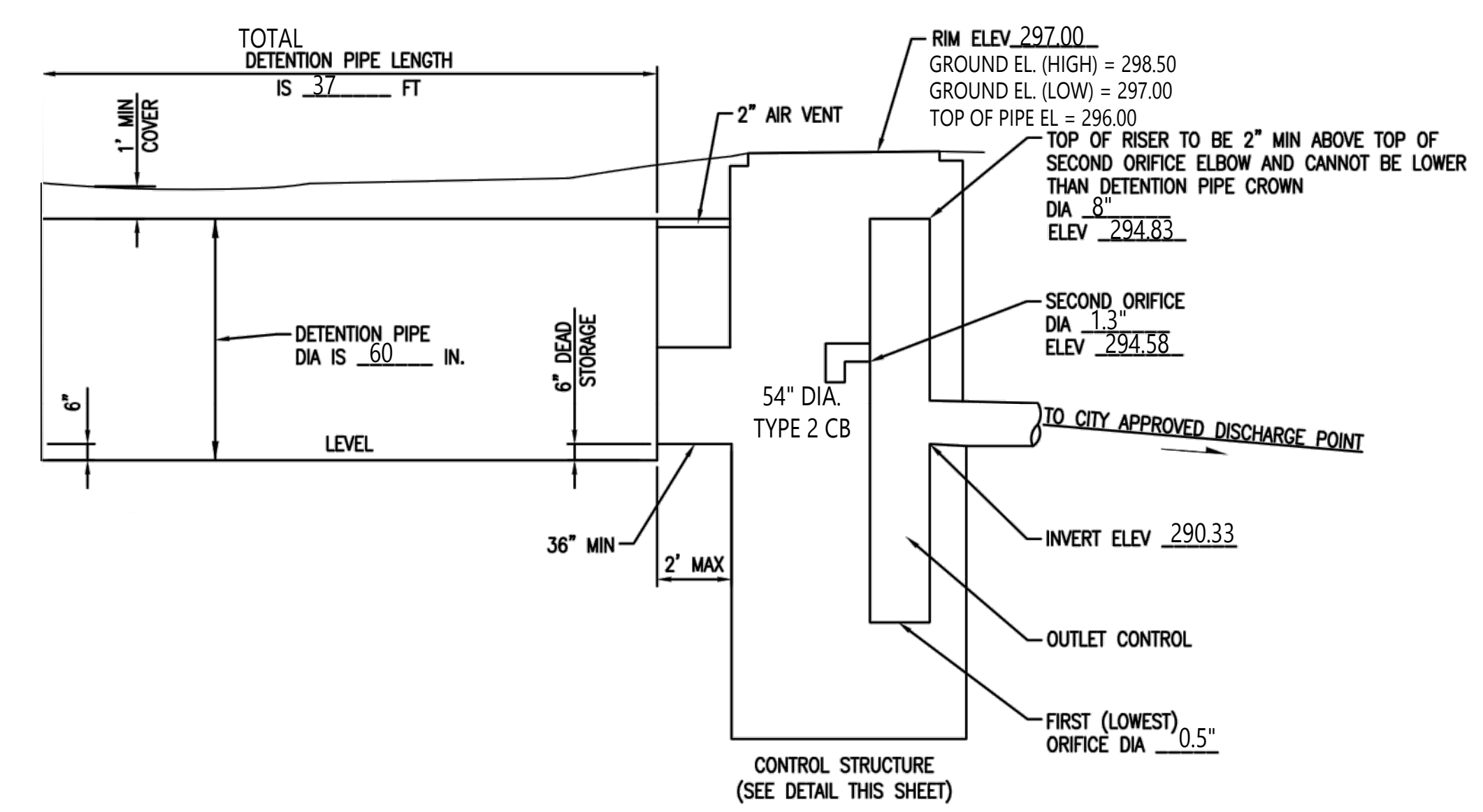

ON-SITE DETENTION SYSTEM  
 NOT TO SCALE (ENGINEER TO FILL IN BLANKS)

ON-SITE DETENTION SYSTEM NOTES:

- CALL DEVELOPMENT SERVICES (206-275-7605) 24 HOURS IN ADVANCE FOR A DETENTION SYSTEM INSPECTION BEFORE BACKFILLING AND FOR FINAL INSPECTIONS.
- RESPONSIBILITY FOR OPERATION AND MAINTENANCE OF DRAINAGE SYSTEMS ON PRIVATE PROPERTY IS RESPONSIBILITY OF THE PROPERTY OWNER. MATERIAL ACCUMULATED IN THE STORAGE PIPE MUST BE REMOVED FROM CATCH BASINS TO ALLOW PROPER OPERATION. THE OUTLET CONTROL ORIFICE MUST BE KEPT OPEN AT ALL TIMES.
- PIPE MATERIAL, JOINT, AND PROTECTIVE TREATMENT SHALL BE IN ACCORDANCE WITH SECTION 7.04 AND 9.05 OF THE WSDOT STANDARD SPECIFICATION FOR ROAD, BRIDGE, AND MUNICIPAL CONSTRUCTION, LATEST VERSION. SUCH MATERIALS INCLUDE THE FOLLOWING: LINED CORRUGATED POLYETHYLENE PIPE (LCPE), ALUMINIZED TYPE 2 CORRUGATED STEEL PIPE AND PIPE ARCH (MEETS AASHTO DESIGNATIONS M274 AND M36), CORRUGATED OR SPIRAL RIB ALUMINUM PIPE, OR REINFORCED CONCRETE PIPE. CORRUGATED STEEL PIPE IS NOT ALLOWED.
- FOOTING DRAINS SHALL NOT BE CONNECTED TO THE DETENTION SYSTEM.

SEE C3 FOR DRAINAGE SITE PLAN

4102 Island Crest Way SFR  
 Site Address: 4102 Island Crest Way  
 Jurisdiction: Mercer Island  
 Parcel No.: 545030-0025  
 Applicant: Hien Phan  
 Permit No.:  
 Interlaken Project No.: SEA-22-190

Interlaken Engineering and Design, PLLC  
 Seattle, WA | (206) 470-9572  
 www.interlakenengineering.com

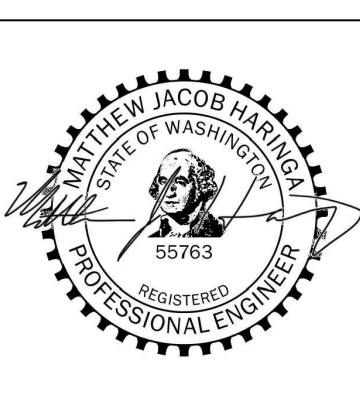

Revisions:

C4  
 Detention Detail  
 Scale: As Noted